

ASSISTANT EXECUTIVE ENGINEERS (MECHANICAL)

NOTIFICATION NO: 12/2015

MECHANICAL ENGINEERING PAPER

DATE OF EXAM: 18/10/2015 AN

	Group 1
Group Number :	1
Group Id :	12
Group Maximum Duration :	0
Group Minimum Duration :	150
Revisit allowed for view? :	No
Revisit allowed for edit? :	No
Break time:	0
Group Marks:	300.0

	Mechanical Engineering
Section Id :	12
Section Number :	1
Section type :	Online
Mandatory or Optional:	Mandatory
Number of Questions:	150
Number of Questions to be attempted:	150
Section Marks:	300.0

Sub-Section Number:	1
Sub-Section Id:	19
Question Shuffling Allowed :	Yes

Question Number : 1 Question Id : 1651 Question Type : MCQ Option Shuffling : No

Correct : 2.0 Wrong : 0.0

Two balls of equal mass and of Perfectly elastic material are lying on the floor. One of the ball with velocity V is made to struck the second ball. Both the balls after impact will move with a velocity

Options :

1. V
2. $V/2$
3. $V/4$

Question Number : 2 Question Id : 1652 Question Type : MCQ Option Shuffling : No

Correct : 2.0 Wrong : 0.0

The condition for a truss to be perfect is, where m = number of members and J = number of joints

Options :

1. $m = 2j - 3$
2. $m > 2j - 3$
3. $m < 2j - 3$
4. $m \geq 2j - 3$

Question Number : 3 Question Id : 1653 Question Type : MCQ Option Shuffling : No

Correct : 2.0 Wrong : 0.0

In virtual work Principle, the work done by self weight of the body is taken into consideration, when

Options :

1. centre of gravity moves vertically
2. centre of gravity moves horizontally
3. shear centre moves horizontally
4. shear centre moves vertically

Question Number : 4 Question Id : 1654 Question Type : MCQ Option Shuffling : No

Correct : 2.0 Wrong : 0.0

The co-efficient of restitution of a perfectly plastic impact is

Options :

1. 0
2. 1
3. 2
4. 3

Question Number : 5 Question Id : 1655 Question Type : MCQ Option Shuffling : No

Correct : 2.0 Wrong : 0.0

A lead ball with a certain velocity is made to strike a wall, it falls down, but rubber ball of same mass and with same velocity strikes the same wall, it rebounds. Select the correct reason from the following:

Options :

1. both the balls undergo an equal change in momentum
2. the change in momentum suffered by rubber ball is more than the lead ball
3. the change in momentum suffered by rubber is less than the lead ball
4. none of the above

Question Number : 6 Question Id : 1656 Question Type : MCQ Option Shuffling : No

Correct : 2.0 Wrong : 0.0

During elastic impact, the relative velocity of the two bodies after impact is _____ the relative velocity of the two bodies before impact

Options :

1. equal to
2. equal and opposite to
3. less than
4. greater than

Question Number : 7 Question Id : 1657 Question Type : MCQ Option Shuffling : No

Correct : 2.0 Wrong : 0.0

A Particle is dropped from a height of 3m on a horizontal floor, which has a coefficient of restitution with the ball of $1/2$. The height to which the ball will rebound after striking the floor is

Options :

1. 0.5 m
2. 0.75 m
3. 1.0 m
4. 1.5 m

Question Number : 8 Question Id : 1658 Question Type : MCQ Option Shuffling : No

Correct : 2.0 Wrong : 0.0

A bullet of mass 1 kg is fired with a velocity of u m/s from a gun of mass 10 kg. The ratio of kinetic energies of bullet and gun is

Options :

1. 10
2. 11
3. 1.1
4. 0.1

Question Number : 9 Question Id : 1659 Question Type : MCQ Option Shuffling : No

Correct : 2.0 Wrong : 0.0

If u_1 and u_2 are the velocities of two moving bodies in the same direction before impact and v_1 and v_2 are their velocities after impact, then co-efficient of restitution is given by

Options :

1. $\frac{v_1 - v_2}{u_1 - u_2}$
2. $\frac{v_2 - v_1}{u_1 - u_2}$
3. $\frac{u_1 - u_2}{v_1 - v_2}$
4. $\frac{u_2 + u_1}{v_2 + v_1}$

Question Number : 10 Question Id : 1660 Question Type : MCQ Option Shuffling : No

Correct : 2.0 Wrong : 0.0

Which of the following statement is correct?

Options :

1. the algebraic sum of the forces, constituting the couple is zero
2. the algebraic sum of the forces, constituting the couple, about any point is same
3. A couple cannot be balanced by a single force but can be balanced only by a couple of opposite sense
4. all statements

Question Number : 11 Question Id : 1661 Question Type : MCQ Option Shuffling : No

Correct : 2.0 Wrong : 0.0

For a long slender column of uniform cross section, the ratio of critical buckling load for the case with both ends closed to the case with both ends hinged is

Options :

1. 1
2. 2
3. 4
4. 8

Question Number : 12 Question Id : 1662 Question Type : MCQ Option Shuffling : No

Correct : 2.0 Wrong : 0.0

a circular rod of length 'L' and area of cross section 'A' has a modulus of elasticity 'E' and co-efficient of thermal expansion ' α '. One end of the rod is fixed and the other end is free. If the temperature of the rod is increased by ΔT , then

Options :

1. stress developed in the rod is $E \alpha \Delta T$ and strain developed in the rod is $\alpha \Delta T$
2. Both stress and strain developed in the rod are zero
3. stress developed in the rod is zero and strain developed in the rod is $\alpha \Delta T$
4. stress developed in the rod is $E \alpha \Delta T$ and strain developed in the rod is zero

Question Number : 13 Question Id : 1663 Question Type : MCQ Option Shuffling : No

Correct : 2.0 Wrong : 0.0

The simply supported beam 'A' of length 'l' carries a central point load 'W'. Another beam 'B' is loaded with a uniformly distributed load such that the total load on the beam is W. The ratio of maximum deflections between beams A and B is

Options :

1. 5/8
2. 8/5
3. 5/4
4. 4/5

Question Number : 14 Question Id : 1664 Question Type : MCQ Option Shuffling : No

Correct : 2.0 Wrong : 0.0

If the depth is kept constant for a beam of uniform strength, then its width will vary in proportional to (where M = Bending moment)

Options :

1. M
2. \sqrt{M}
3. M^2
4. M^3

Question Number : 15 Question Id : 1665 Question Type : MCQ Option Shuffling : No

Correct : 2.0 Wrong : 0.0

The radius of the Mohr's circle is equal to

Options :

1. sum of two Principal stresses

- <https://universitynews.in>
2. difference of two principal stresses
 3. half the sum of two principal stresses
 4. half the difference of two principal stresses

Question Number : 16 Question Id : 1666 Question Type : MCQ Option Shuffling : No

Correct : 2.0 Wrong : 0.0

The rectangular beam 'A' has length l , width b and depth d . Another beam 'B' has the same length and width but depth is double that of 'A'. The elastic strength of beam B will be _____ as compared to beam A.

Options :

1. same
2. double
3. four times
4. six times

Question Number : 17 Question Id : 1667 Question Type : MCQ Option Shuffling : No

Correct : 2.0 Wrong : 0.0

If the diameter of a long column is reduced by 20%, the percentage of reduction in Euler buckling load is

Options :

1. 4
2. 36
3. 49
4. 59

Question Number : 18 Question Id : 1668 Question Type : MCQ Option Shuffling : No

Correct : 2.0 Wrong : 0.0

The ratio of the maximum deflections of a beam simply supported at its ends with an isolated central load and that of with a uniformly distributed load over its entire length is

Options :

1. 1
2. $3/2$
3. $2/3$
4. $1/3$

Question Number : 19 Question Id : 1669 Question Type : MCQ Option Shuffling : No

Correct : 2.0 Wrong : 0.0

For an isotropic, homogeneous and linearly elastic material, which obeys Hook's law, the number of independent elastic constant is

Options :

1. 1
2. 2
3. 3
4. 6

Question Number : 20 Question Id : 1670 Question Type : MCQ Option Shuffling : No

Correct : 2.0 Wrong : 0.0

Two beams of equal cross sectional area are subjected to equal bending moment. If one beam has square cross section and the other has circular cross section, then

Options :

1. Both beams will be equally strong

- <https://universitynews.in>
- Circular section beam will be stronger
 - Square section beam will be stronger
 - the strength of the beam will depend on the nature of loading

Question Number : 21 Question Id : 1671 Question Type : MCQ Option Shuffling : No
Correct : 2.0 Wrong : 0.0

A planar mechanism has 6 links with 6 lower pairs and 2 higher pairs. Then the degree of freedom of mechanism as per Gruebler's Criterion is

Options :

- 1
- 2
- 3
- 0

Question Number : 22 Question Id : 1672 Question Type : MCQ Option Shuffling : No
Correct : 2.0 Wrong : 0.0

For two wheels of equal size with 20° Pressure angle and addendum equal to one module, the minimum number of teeth on each wheel must be

Options :

- 10
- 13
- 15
- 17

Question Number : 23 Question Id : 1673 Question Type : MCQ Option Shuffling : No
Correct : 2.0 Wrong : 0.0

In dynamic analysis of planar Mechanisms, the equivalent offset inertia force may be kept at a distance (h) of

Options :

1.
$$h = \frac{k^2 \alpha}{f_g}$$

2.
$$h = \frac{k \alpha}{f_g}$$

3.
$$h = k^2 \alpha$$

4.
$$h = \frac{k^2 \alpha^2}{f_g}$$

Question Number : 24 Question Id : 1674 Question Type : MCQ Option Shuffling : No
Correct : 2.0 Wrong : 0.0

Which one of the following is not an inversion of double slider crank mechanism

Options :

- Elliptical trammel

2. <https://universitynews.in>

3. Scotch yoke Mechanism
4. Beam engine Mechanism

Question Number : 25 Question Id : 1675 Question Type : MCQ Option Shuffling : No Correct : 2.0 Wrong : 0.0

The following mechanism has got coriolis component of acceleration

Options :

1. slider crank mechanism
2. whitworth quick return mechanism
3. steering gear mechanism
4. pantograph

Question Number : 26 Question Id : 1676 Question Type : MCQ Option Shuffling : No Correct : 2.0 Wrong : 0.0

Which of the following governor is used to drive gramophone

Options :

1. Hartnell governor
2. Watt governor
3. Porter governor
4. Pickering governor

Question Number : 27 Question Id : 1677 Question Type : MCQ Option Shuffling : No Correct : 2.0 Wrong : 0.0

Minimum number of teeth of standard proportion with involute profile and 20° pressure angle helical gear of helix angle 10° is

Options :

1. 12
2. 18
3. 32
4. 22

Question Number : 28 Question Id : 1678 Question Type : MCQ Option Shuffling : No Correct : 2.0 Wrong : 0.0

The rotor of a ship rotates in clockwise direction when viewed from the stern and the ship takes a left turn. The effect of the gyroscopic couple acting on it will be

Options :

1. To raise the bow and stern
2. to lower the bow and stern
3. to raise the bow and lower the stern
4. to raise the stern and lower the bow

Question Number : 29 Question Id : 1679 Question Type : MCQ Option Shuffling : No Correct : 2.0 Wrong : 0.0

The effort of a governor is the force exerted by the governor on the

Options :

1. Balls
2. Sleeve

<https://universitynews.in>

3. ✘ upper links

4. ✘ Lower links

Question Number : 30 Question Id : 1680 Question Type : MCQ Option Shuffling : No

Correct : 2.0 Wrong : 0.0

The magnitude of coriolis component of acceleration is (Where v = velocity, ω = angular velocity)

Options :

1. ✘ $2v\omega$

2. ✘ $2v^2\omega$

3. ✘ $v\omega$

4. ✘ $2v\omega^2$

Question Number : 31 Question Id : 1681 Question Type : MCQ Option Shuffling : No

Correct : 2.0 Wrong : 0.0

For high speed cams the recommended type of follower motion is

Options :

1. ✘ uniform

2. ✘ parabolic

3. ✘ cycloidal

4. ✘ SHM

Question Number : 32 Question Id : 1682 Question Type : MCQ Option Shuffling : No

Correct : 2.0 Wrong : 0.0

The swaying couple is maximum or minimum when the angle of inclination of the crank to the line of stroke is $\theta =$

Options :

1. ✘ 90° and 225°

2. ✘ 135° and 180°

3. ✘ 180° and 225°

4. ✘ 135° and 315°

Question Number : 33 Question Id : 1683 Question Type : MCQ Option Shuffling : No

Correct : 2.0 Wrong : 0.0

In automobiles the power is transmitted from gear box to differential through

Options :

1. ✘ Oldham's coupling

2. ✘ Knuckle joint

3. ✘ Hook's joint

4. ✘ Flexible coupling

Question Number : 34 Question Id : 1684 Question Type : MCQ Option Shuffling : No

Correct : 2.0 Wrong : 0.0

A shaft carrying two rotors at its ends will have

Options :

- No node
- One node
- Two nodes
- Three nodes

Question Number : 35 Question Id : 1685 Question Type : MCQ Option Shuffling : No

Correct : 2.0 Wrong : 0.0

In vibration isolation system, if ω/ω_n is less than $\sqrt{2}$, then for all values of the damping factor, the transmissibility will be where ω -circular frequency of excitation in rad/s and ω_n = Natural circular frequency, rad/s

Options :

- Less than unity
- Equal to unity
- Greater than unity
- Zero

Question Number : 36 Question Id : 1686 Question Type : MCQ Option Shuffling : No

Correct : 2.0 Wrong : 0.0

when $\omega/\omega_n = 1$, the transmissibility is
where ω = frequency of excitation, rad/s
 ω_n = Natural frequency, rad/s

Options :

- \propto
- 0
- 1
- $\sqrt{2}$

Question Number : 37 Question Id : 1687 Question Type : MCQ Option Shuffling : No

Correct : 2.0 Wrong : 0.0

The amplitude ratio of two successive oscillations of a damped vibratory system is

Options :

- More than one
- less than one
- Equal to one
- Variable

Question Number : 38 Question Id : 1688 Question Type : MCQ Option Shuffling : No

Correct : 2.0 Wrong : 0.0

Seismic vibrations are measured with

Options :

- Richter scale
- Vibrometers
- Accelerometers

Question Number : 39 Question Id : 1689 Question Type : MCQ Option Shuffling : No

Correct : 2.0 Wrong : 0.0

In the spring mass system, if the mass of the system is doubled with spring stiffness halved, the natural frequency of vibration is

Options :

- remains unchanged
- doubled
- halved
- quadrupled

Question Number : 40 Question Id : 1690 Question Type : MCQ Option Shuffling : No

Correct : 2.0 Wrong : 0.0

For forced damped vibration system, the vibration isolation is possible only when

Options :

- $\omega/\omega_n = 1$
- $\omega/\omega_n < 1$
- $\omega/\omega_n > \sqrt{2}$
- $\omega/\omega_n < \sqrt{2}$

Question Number : 41 Question Id : 1691 Question Type : MCQ Option Shuffling : No

Correct : 2.0 Wrong : 0.0

If the load on the ball bearing is reduced to half, the life of the ball bearing will

Options :

- Increase 8 times
- increase 4 times
- increase 2 times
- no change

Question Number : 42 Question Id : 1692 Question Type : MCQ Option Shuffling : No

Correct : 2.0 Wrong : 0.0

A solid shaft can resist a bending moment of 3 KNM and a twisting moment of 4 KNM together, then the maximum torque (in KNM) that can be applied is

Options :

- 7
- 3.5
- 4.5
- 5

Question Number : 43 Question Id : 1693 Question Type : MCQ Option Shuffling : No

Correct : 2.0 Wrong : 0.0

For a circular cross section beam is subjected to a shearing force F, the maximum shear stress induced will be (where d = diameter)

Options :

- $F / \pi d^2$
- $4F / \pi d^2$

3. ✖ $\frac{2F}{\pi d^2}$

4. ✖ $F/4d^2$

Question Number : 44 Question Id : 1694 Question Type : MCQ Option Shuffling : No

Correct : 2.0 Wrong : 0.0

In design of helical springs the spring index is usually taken as

Options :

1. ✖ 3

2. ✖ 5

3. ✖ 8

4. ✖ 12

Question Number : 45 Question Id : 1695 Question Type : MCQ Option Shuffling : No

Correct : 2.0 Wrong : 0.0

When a nut is tightened by placing a washer below it, the bolt will be subjected to the following type of loads

Options :

1. ✖ Compression

2. ✖ Tension

3. ✖ Shear

4. ✖ Combined loads

Question Number : 46 Question Id : 1696 Question Type : MCQ Option Shuffling : No

Correct : 2.0 Wrong : 0.0

For brittle materials the following theory is used

Options :

1. ✖ Maximum Normal stress theory

2. ✖ Maximum shear stress theory

3. ✖ Distortion energy theory

4. ✖ all of the above

Question Number : 47 Question Id : 1697 Question Type : MCQ Option Shuffling : No

Correct : 2.0 Wrong : 0.0

The following coupling is used to connect two parallel shafts having small distance between the axes

Options :

1. ✖ Muff coupling

2. ✖ Flange coupling

3. ✖ Oldham's coupling

4. ✖ Hooke's Joint

Question Number : 48 Question Id : 1698 Question Type : MCQ Option Shuffling : No

Correct : 2.0 Wrong : 0.0

Lame's equation is used to find stresses in

Options :

1. ✖ Thin cylinders

2. ✖ Thick cylinders

3. ✖ Gears

Question Number : 49 Question Id : 1699 Question Type : MCQ Option Shuffling : No

Correct : 2.0 Wrong : 0.0

Tearing efficiency of rivet is given by (P = pitch of rivets, d = diameter of rivet hole)

Options :

- $(2p-d)/p$
- $(p-d)/4p$
- $(p-2d)/p$
- $(p-d)/p$

Question Number : 50 Question Id : 1700 Question Type : MCQ Option Shuffling : No

Correct : 2.0 Wrong : 0.0

For self locking of screws the efficiency cannot be more than

Options :

- 40%
- 50%
- 100%
- 20%

Question Number : 51 Question Id : 1701 Question Type : MCQ Option Shuffling : No

Correct : 2.0 Wrong : 0.0

Falling drops of rain acquire spherical shape on account of

Options :

- Viscosity
- Surface Tension
- Vapour Pressure
- Compressibility

Question Number : 52 Question Id : 1702 Question Type : MCQ Option Shuffling : No

Correct : 2.0 Wrong : 0.0

Select the correct statement

Options :

- Absolute pressure = Gauge pressure - Atmospheric pressure
- Gauge pressure = Absolute pressure - Atmospheric pressure
- Absolute pressure = Atmospheric pressure + Vacuum pressure
- Gauge pressure = Atmospheric pressure + Vacuum pressure

Question Number : 53 Question Id : 1703 Question Type : MCQ Option Shuffling : No

Correct : 2.0 Wrong : 0.0

A practical example of steady non-uniform flow is given as the

Options :

- Motion of the river around the bridge piers
- Steadily increasing flow through the pipe
- Steadily increasing flow through a reducing section
- Constant discharge through a long, straight tapering pipe

Question Number : 54 Question Id : 1704 Question Type : MCQ Option Shuffling : No

Correct : 2.0 Wrong : 0.0

Steady flow occurs when -----

Options :

1. ✖ Conditions do not change with time at any point
2. ✖ Conditions are the same at adjacent points at any instant
3. ✖ when $\frac{\partial v}{\partial x}$ is constant
4. ✖ Conditions change steadily with the time

Question Number : 55 Question Id : 1705 Question Type : MCQ Option Shuffling : No

Correct : 2.0 Wrong : 0.0

If stream function $\psi = 2xy$, then the velocity at a point (1,2) is equal to ___

Options :

1. ✖ 2
2. ✖ 4
3. ✖ $\sqrt{20}$
4. ✖ 16

Question Number : 56 Question Id : 1706 Question Type : MCQ Option Shuffling : No

Correct : 2.0 Wrong : 0.0

For laminar flow in pipes the momentum correction factor is-----

Options :

1. ✖ less than 1
2. ✖ 1.03
3. ✖ 1.33
4. ✖ 2

Question Number : 57 Question Id : 1707 Question Type : MCQ Option Shuffling : No

Correct : 2.0 Wrong : 0.0

The hydraulic gradient line is -----

Options :

1. ✖ Always above the energy gradient line
2. ✖ The velocity head below the energy gradient line
3. ✖ Always above the closed conduit
4. ✖ Always sloping down in the direction of flow

Question Number : 58 Question Id : 1708 Question Type : MCQ Option Shuffling : No

Correct : 2.0 Wrong : 0.0

The energy correction factor for laminar flow through a circular pipe is -----

Options :

1. ✖ 1
2. ✖ 2
3. ✖ 3
4. ✖ 4

Question Number : 59 Question Id : 1709 Question Type : MCQ Option Shuffling : No

Correct : 2.0 Wrong : 0.0

The turbulent flow has -----

Options :

1. Streak line motion
2. Random orientation of particles
3. streamline motion
4. parabolic velocity distribution

Question Number : 60 Question Id : 1710 Question Type : MCQ Option Shuffling : No

Correct : 2.0 Wrong : 0.0

The relation between surface tension ' σ ' and difference of pressure 'p' between the inside and outside of a liquid drops is given as _____

Options :

1. $p = \frac{\sigma}{8d}$
2. $p = \frac{\sigma}{6d}$
3. $p = \frac{\sigma}{2d}$
4. $p = \frac{4\sigma}{d}$

Question Number : 61 Question Id : 1711 Question Type : MCQ Option Shuffling : No

Correct : 2.0 Wrong : 0.0

The units of thermal conductivity are -----

Options :

1. w/m^2k
2. w/mK
3. J/m^2k
4. J/m^3k

Question Number : 62 Question Id : 1712 Question Type : MCQ Option Shuffling : No

Correct : 2.0 Wrong : 0.0

Transient heat conduction means -----

Options :

1. Very little heat transfer
2. Heat transfer for a short time
3. Heat transfer with a small temperature difference
4. conduction when temperature varies with time

Question Number : 63 Question Id : 1713 Question Type : MCQ Option Shuffling : No

Correct : 2.0 Wrong : 0.0

A cylindrical pipe of length l has inner radius r_1 and outer radius r_2 . The interior of the pipe carries a hot water of temperature T_1 where as the outer surface is at temperature T_2 . The rate of conduction heat loss per unit length of the pipe is given as _____

Options :

1. $\frac{4\pi kl(T_1 - T_2)}{r_2 - r_1}$
2. $\frac{2\pi kl(T_1 - T_2)}{r_2 - r_1}$
3. $\frac{4\pi kl(T_1 - T_2)}{\ln(r_2 / r_1)}$
4. $\frac{2\pi kl(T_1 - T_2)}{\ln(r_2 / r_1)}$

Question Number : 64 Question Id : 1714 Question Type : MCQ Option Shuffling : No Correct : 2.0 Wrong : 0.0

The critical radius of insulation of cylindrical rod / wire is given by _____
(where k = thermal conductivity, h_o = heat transfer co-efficient)

Options :

1. h_o/k
2. k/h_o
3. $2h_o/k$
4. $2k/h_o$

Question Number : 65 Question Id : 1715 Question Type : MCQ Option Shuffling : No Correct : 2.0 Wrong : 0.0

The fouling factor in case of heat exchangers is given by ___

Options :

1. $\frac{1}{U_{dirty}} + \frac{1}{U_{clean}}$

$$\frac{1}{U_{dirty}} - \frac{1}{U_{clean}}$$

2. ✖

$$\frac{1}{U_{dirty}}$$

3. ✖

$$\frac{1}{U_{dirty}} - 1$$

4. ✖

Question Number : 66 Question Id : 1716 Question Type : MCQ Option Shuffling : No
Correct : 2.0 Wrong : 0.0

The radius of a bare cable carrying electric current before providing insulation should be _____

Options :

1. ✖ Equal to r_c
2. ✖ Less than r_c
3. ✖ Greater than r_c
4. ✖ Twice of r_c

Question Number : 67 Question Id : 1717 Question Type : MCQ Option Shuffling : No
Correct : 2.0 Wrong : 0.0

IN heat transfer NTU is given by _____

(Where U=heat transfer co-efficient, A= surface area, C= Heat capacitance, min = Minimum, max = Maximum)

Options :

$$\frac{UA}{C_{min}}$$

1. ✖

$$\frac{U}{C_{min}}$$

2. ✖

$$\frac{UA}{C_{max}}$$

3. ✖

4. ✖

Question Number : 68 Question Id : 1718 Question Type : MCQ Option Shuffling : No

Correct : 2.0 Wrong : 0.0

A thermodynamic system is referred to be an isolated system when there is a transfer of _____ across the system boundaries

Options :

1. ✖ only mass
2. ✖ only energy
3. ✖ both mass and energy
4. ✖ neither mass nor energy

Question Number : 69 Question Id : 1719 Question Type : MCQ Option Shuffling : No

Correct : 2.0 Wrong : 0.0

Which one of the properties given below is an intensive property of the system

Options :

1. ✖ composition
2. ✖ volume
3. ✖ kinetic energy
4. ✖ entropy

Question Number : 70 Question Id : 1720 Question Type : MCQ Option Shuffling : No

Correct : 2.0 Wrong : 0.0

The internal energy of an ideal gas is function of

Options :

1. ✖ Pressure only
2. ✖ absolute temperature only
3. ✖ pressure and volume
4. ✖ pressure, volume and temperature

Question Number : 71 Question Id : 1721 Question Type : MCQ Option Shuffling : No

Correct : 2.0 Wrong : 0.0

Work output from a system is at the expense of internal energy is a non flow process carried out

Options :

1. ✖ at constant pressure
2. ✖ at constant volume
3. ✖ adiabatically
4. ✖ polytropically

Question Number : 72 Question Id : 1722 Question Type : MCQ Option Shuffling : No

Correct : 2.0 Wrong : 0.0

The process involved in a Carnot cycle are

Options :

1. ✖ two adiabatic processes and two constant volume process
2. ✖ two adiabatic processes and two isothermal processes

3. two constant pressure processes
4. two constant pressure and two constant volume processes

Question Number : 73 Question Id : 1723 Question Type : MCQ Option Shuffling : No
Correct : 2.0 Wrong : 0.0

Availability of a System at any given stage is

Options :

1. a property of the system
2. the total energy of the system
3. the maximum work obtainable as the system goes to dead state
4. the maximum useful work obtainable as the system goes to dead state

Question Number : 74 Question Id : 1724 Question Type : MCQ Option Shuffling : No
Correct : 2.0 Wrong : 0.0

Which of the following gasses will have the maximum value of gas constant R

Options :

1. nitrogen
2. carbon dioxide
3. sulphur dioxide
4. oxygen

Question Number : 75 Question Id : 1725 Question Type : MCQ Option Shuffling : No
Correct : 2.0 Wrong : 0.0

The specific heat of gas remains constant at all pressure and temperatures. This statement pertains to

Options :

1. Joule's law
2. Regnault's law
3. Avogadro's law
4. Maxwell law

Question Number : 76 Question Id : 1726 Question Type : MCQ Option Shuffling : No
Correct : 2.0 Wrong : 0.0

Slow and progressive deformation of metals under constant stress is called

Options :

1. Fatigue
2. Creep
3. Toughness
4. Hardness

Question Number : 77 Question Id : 1727 Question Type : MCQ Option Shuffling : No
Correct : 2.0 Wrong : 0.0

Austenite is having crystal structure

Options :

1. bcc
2. hcp
3. fcc
4. orthorhombic

Question Number : 78 Question Id : 1728 Question Type : MCQ Option Shuffling : No
Correct : 2.0 Wrong : 0.0

The hardening of machine tool guideways is usually carried out by

Options :

- Flame hardening
- Induction hardening
- Vacuum hardening
- Furnace hardening

Question Number : 79 Question Id : 1729 Question Type : MCQ Option Shuffling : No
Correct : 2.0 Wrong : 0.0

Austempering produces

Options :

- Pearlite
- Martensite
- Austenite
- Bainite

Question Number : 80 Question Id : 1730 Question Type : MCQ Option Shuffling : No
Correct : 2.0 Wrong : 0.0

Retained austenite will be produced during quenching of materials

Options :

- Hypoeutectic steels
- Eutectoid steels
- Hypereutectoid steels
- Cast Irons

Question Number : 81 Question Id : 1731 Question Type : MCQ Option Shuffling : No
Correct : 2.0 Wrong : 0.0

Yield point phenomenon appears in

Options :

- Low carbon steels
- Medium Carbon steels
- High Carbon steels
- Cast Irons

Question Number : 82 Question Id : 1732 Question Type : MCQ Option Shuffling : No
Correct : 2.0 Wrong : 0.0

The number of phases present in equilibrium at eutectic point

Options :

- 0
- 1
- 2
- 3

Question Number : 83 Question Id : 1733 Question Type : MCQ Option Shuffling : No
Correct : 2.0 Wrong : 0.0

Crater wear of single point cutting tool appears due to

Options :

1. Fatigue
2. Corrosion
3. Impact
4. Diffusion

Question Number : 84 Question Id : 1734 Question Type : MCQ Option Shuffling : No

Correct : 2.0 Wrong : 0.0

Continuous chips during machining forms when

Options :

1. speed is high, feed is low
2. speed is high, feed is high
3. speed is low, feed is low
4. speed is low, feed is high

Question Number : 85 Question Id : 1735 Question Type : MCQ Option Shuffling : No

Correct : 2.0 Wrong : 0.0

When the space between two consecutive abrasive is less in grinding, upon machining ductile materials, hot chips weld these abrasives and after some time wheel is rubbing over work without cutting. This phenomenon is called

Options :

1. Glazing
2. Loading
3. Dressing
4. Trueing

Question Number : 86 Question Id : 1736 Question Type : MCQ Option Shuffling : No

Correct : 2.0 Wrong : 0.0

For unconventional machining process, following is the correct sequence of decreasing order of Material Removal Rate (MRR)

Options :

1. ECM > EDM > USM
2. ECM > USM > EDM
3. USM > EDM > ECM
4. USM > ECM > EDM

Question Number : 87 Question Id : 1737 Question Type : MCQ Option Shuffling : No

Correct : 2.0 Wrong : 0.0

In ultrasonic machining, Material Removal Rate with respect to grain size increase in

Options :

1. increases
2. decreases
3. increases and decreases
4. decreases and increases

Question Number : 88 Question Id : 1738 Question Type : MCQ Option Shuffling : No

Correct : 2.0 Wrong : 0.0

Point angle in drills are kept low for machining ductile materials to take advantage of

Options :

1. Thinner chips

2. ✖ <https://universitynews.in>

3. ✖ Low heat developed
4. ✖ Lesser cutting forces

Question Number : 89 Question Id : 1739 Question Type : MCQ Option Shuffling : No
Correct : 2.0 Wrong : 0.0

Very accurate screw threads can be manufactured by

Options :

1. ✖ Milling
2. ✖ Grinding
3. ✖ Rolling
4. ✖ Chasing

Question Number : 90 Question Id : 1740 Question Type : MCQ Option Shuffling : No
Correct : 2.0 Wrong : 0.0

When machining parameters are kept constant, tool life will be less in

Options :

1. ✖ down milling
2. ✖ up milling
3. ✖ face milling
4. ✖ end milling

Question Number : 91 Question Id : 1741 Question Type : MCQ Option Shuffling : No
Correct : 2.0 Wrong : 0.0

The ratio between Iron oxide and Aluminium is Thermit is

Options :

1. ✖ 1:1
2. ✖ 1:3
3. ✖ 3:1
4. ✖ 1:2

Question Number : 92 Question Id : 1742 Question Type : MCQ Option Shuffling : No
Correct : 2.0 Wrong : 0.0

Which statement is correct in coated electrode arc welding process

Options :

1. ✖ Both rod and flux melts simultaneously
2. ✖ Coating melts first then rod material
3. ✖ Rod melts first then coating material
4. ✖ Rod only melts and material coating does not melt

Question Number : 93 Question Id : 1743 Question Type : MCQ Option Shuffling : No
Correct : 2.0 Wrong : 0.0

The temperature of Oxidized flame in gas welding is

Options :

1. ✖ 2900° c
2. ✖ 3200° c
3. ✖ 3480° c

Question Number : 94 Question Id : 1744 Question Type : MCQ Option Shuffling : No Correct : 2.0 Wrong : 0.0

Collapsible tubes are manufactured by

Options :

1. ✖ Direct extrusion
2. ✖ Indirect extrusion
3. ✖ Hydrostatic extrusion
4. ✖ Impact extrusion

Question Number : 95 Question Id : 1745 Question Type : MCQ Option Shuffling : No Correct : 2.0 Wrong : 0.0

Which of the following process belongs to forging operation

Options :

1. ✖ Fulluring
2. ✖ Welding
3. ✖ Drawing
4. ✖ Piercing

Question Number : 96 Question Id : 1746 Question Type : MCQ Option Shuffling : No Correct : 2.0 Wrong : 0.0

Aluminium is very difficult to weld because

Options :

1. ✖ Very light material
2. ✖ It's melting point is low
3. ✖ Do not form bond so easily
4. ✖ Forms a layer of Al_2O_3 on its surface

Question Number : 97 Question Id : 1747 Question Type : MCQ Option Shuffling : No Correct : 2.0 Wrong : 0.0

Sweep patterns are used for moulding parts having the shape of

Options :

1. ✖ Rectangular
2. ✖ Complex shape
3. ✖ Square
4. ✖ Symmetrical

Question Number : 98 Question Id : 1748 Question Type : MCQ Option Shuffling : No Correct : 2.0 Wrong : 0.0

Ornaments, Statues and toys casted by following process

Options :

1. ✖ Die Casting
2. ✖ Slush Casting
3. ✖ Continuous Casting
4. ✖ Centrifugal Casting

Question Number : 99 Question Id : 1750 Question Type : MCQ Option Shuffling : No

Correct : 2.0 Wrong : 0.0

Which of the following abrasive will be used for grinding tool steel and high speed steel

Options :

- Diamond
- SiC
- Al_2O_3
- Boron Carbide

Question Number : 100 Question Id : 1750 Question Type : MCQ Option Shuffling : No

Correct : 2.0 Wrong : 0.0

The term allowance in limits and fits is usually referred by

Options :

- Minimum clearance between shaft and hole
- Maximum clearance between shaft and hole
- Difference of tolerance at shaft and hole
- Difference between maximum and minimum size of hole

Question Number : 101 Question Id : 1751 Question Type : MCQ Option Shuffling : No

Correct : 2.0 Wrong : 0.0

Autocollimators are used to check

Options :

- only straightness
- only flatness
- Both flatness and straightness
- Roundness

Question Number : 102 Question Id : 1752 Question Type : MCQ Option Shuffling : No

Correct : 2.0 Wrong : 0.0

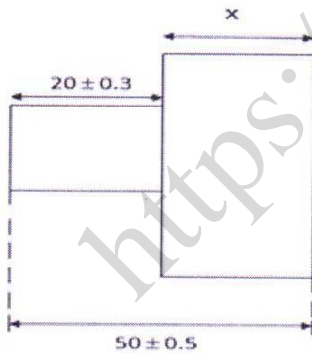

The tolerances of 'x' in the given figure

Options :

- 30 ± 0.2
- 30 ± 0.5
- 30 ± 0.3
- 30 ± 0.8

Question Number : 103 Question Id : 1753 Question Type : MCQ Option Shuffling : No

Correct : 2.0 Wrong : 0.0

The most accurate robot is

Options :

1. Cartesian robot
2. Polar robot
3. spherical robot
4. Articulated

Question Number : 104 Question Id : 1754 Question Type : MCQ Option Shuffling : No

Correct : 2.0 Wrong : 0.0

Sine bars are specified by

Options :

1. Its total length
2. Centre distance between rolls
3. Size of rollers
4. Distance between rollers and upper distance

Question Number : 105 Question Id : 1755 Question Type : MCQ Option Shuffling : No

Correct : 2.0 Wrong : 0.0

Internal gear can be made by

Options :

1. hobbing
2. gear shaping with rack cutter
3. gear shaping with pinious cutter
4. gear milling

Question Number : 106 Question Id : 1756 Question Type : MCQ Option Shuffling : No

Correct : 2.0 Wrong : 0.0

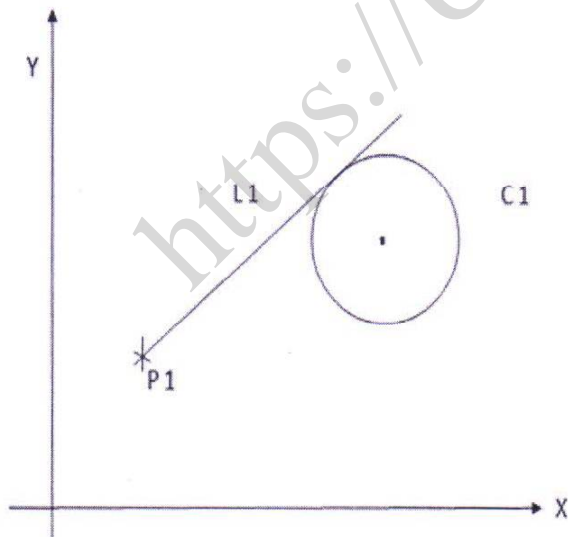

As shown in Figure 'L1' is expressed in APT as

Options :

1. L1=LINE/TANTO C1

2. ✖ <https://universitynews.in>
3. ✖ L1=LINE/P1, LFT TANTO C1
4. ✖ L1=LINE/P1, RGT TANTO C1

Question Number : 107 Question Id : 1757 Question Type : MCQ Option Shuffling : No Correct : 2.0 Wrong : 0.0

In EDM process tool is made up of

Options :

1. ✖ Tungaston Carbide
2. ✖ Heat treated alloy steel
3. ✖ Diamond
4. ✖ Brass

Question Number : 108 Question Id : 1758 Question Type : MCQ Option Shuffling : No Correct : 2.0 Wrong : 0.0

Deep drawing process can be best performed on

Options :

1. ✖ Single action Press
2. ✖ Double action Press
3. ✖ Triple action Press
4. ✖ Screw Press

Question Number : 109 Question Id : 1759 Question Type : MCQ Option Shuffling : No Correct : 2.0 Wrong : 0.0

Spinning operation is carried out on a

Options :

1. ✖ Lathe machine
2. ✖ Milling machine
3. ✖ Hydraulic press
4. ✖ Mechanical Press

Question Number : 110 Question Id : 1760 Question Type : MCQ Option Shuffling : No Correct : 2.0 Wrong : 0.0

In 4 high roll mill, the bigger rolls are called

Options :

1. ✖ Back up rolls
2. ✖ Guide rolls
3. ✖ Support rolls
4. ✖ Main rolls

Question Number : 111 Question Id : 1761 Question Type : MCQ Option Shuffling : No Correct : 2.0 Wrong : 0.0

Queuing theory deals with problem of

Options :

1. ✖ Material handling
2. ✖ Reducing the waiting time
3. ✖ Better utilization of man service
4. ✖ Effective use of machines

Question Number : 112 Question Id : 1762 Question Type : MCQ Option Shuffling : No

Correct : 2.0 Wrong : 0.0

ABC analysis deals with

Options :

- Analysis of process charts
- Flow of material
- Ordering schedule of jobs
- Controlling inventory costs

Question Number : 113 Question Id : 1763 Question Type : MCQ Option Shuffling : No

Correct : 2.0 Wrong : 0.0

The term ATC in CNC machine tool means

Options :

- Automatic Tool control
- Automatic Tool Changer
- Automatic Table Contour
- Automatic Tool Coding

Question Number : 114 Question Id : 1764 Question Type : MCQ Option Shuffling : No

Correct : 2.0 Wrong : 0.0

M06 represents the following instruction in CNC programing

Options :

- Program stop
- Tool change
- Coolant on
- Spindle on

Question Number : 115 Question Id : 1765 Question Type : MCQ Option Shuffling : No

Correct : 2.0 Wrong : 0.0

Positive slack in PERT indicates

Options :

- Ahead of schedule
- Beyond of schedule
- As per schedule
- Critical Path

Question Number : 116 Question Id : 1766 Question Type : MCQ Option Shuffling : No

Correct : 2.0 Wrong : 0.0

In linear programming problem when does feasibility change?

Options :

- change in objective functions coefficient
- change in right hand side of feasible region
- Addition of new variavle
- Feasibility does not change

Question Number : 117 Question Id : 1767 Question Type : MCQ Option Shuffling : No

Correct : 2.0 Wrong : 0.0

Earlier Finish time can be regarded as

Options:

1. Earliest start time - activity time
2. Earliest start time + activity time
3. Latest finish time + Activity time
4. Latest finish time - deviation of activity

Question Number : 118 Question Id : 1768 Question Type : MCQ Option Shuffling : No
Correct : 2.0 Wrong : 0.0

Based on final table of simplex LPP is said to have alternate solution if in $(E_j - C_j)$ row

Options :

1. One or more basic variable has zero value
2. Entering variable has negative coefficient
3. Below a non basic variable there is zero
4. Optimum function value is zero

Question Number : 119 Question Id : 1769 Question Type : MCQ Option Shuffling : No
Correct : 2.0 Wrong : 0.0

Simplex problem is considered as infeasible when

Options :

1. All the variables in entering column are negative
2. Variables in the basis are negative
3. Artificial variable is present in basis
4. Pivotal value is negative

Question Number : 120 Question Id : 1770 Question Type : MCQ Option Shuffling : No
Correct : 2.0 Wrong : 0.0

In 6×6 transportation problem degeneracy will not arise if the number of allocations are

Options :

1. 36
2. > 11
3. 11
4. < 11

Question Number : 121 Question Id : 1771 Question Type : MCQ Option Shuffling : No
Correct : 2.0 Wrong : 0.0

Tolerance of gauges can be checked by

Options :

1. optical flat
2. sine bar
3. Auto collimator
4. Spirit level

Question Number : 122 Question Id : 1772 Question Type : MCQ Option Shuffling : No
Correct : 2.0 Wrong : 0.0

The primary objective of crashing in CPM is

Options :

1. To decrease cost
2. To increase cost

3. To decrease project duration
4. To optimise the path

Question Number : 123 Question Id : 1773 Question Type : MCQ Option Shuffling : No

Correct : 2.0 Wrong : 0.0

Service level in inventory is defined as

Options :

1. % age of time consumed during order
2. % age of time where there is stock out
3. % of time during which inventory is available
4. % age of time during which there is production

Question Number : 124 Question Id : 1774 Question Type : MCQ Option Shuffling : No

Correct : 2.0 Wrong : 0.0

In a gas turbine power plant, reheating between the high pressure and low pressure turbine stages will

Options :

1. Improve turbine out put
2. Decrease turbine output
3. Increase compressor work
4. Decrease compressor work

Question Number : 125 Question Id : 1775 Question Type : MCQ Option Shuffling : No

Correct : 2.0 Wrong : 0.0

A diesel and otto cycle have the same compression ratio. The cutoff ratio of the cycle is 'S'. The air standard efficiency of the cycle will be equal when

Options :

1. $S^r - r(S-1) - 1 = 0$
2. $S^r - r(S-1) + 1 = 0$
3. $S^r - r(S+1) + 1 = 0$
4. $S^r - r(S-1) + r = 0$

Question Number : 126 Question Id : 1776 Question Type : MCQ Option Shuffling : No

Correct : 2.0 Wrong : 0.0

The flash chamber in a vapour compression cycle

Options :

1. Increases refrigeration effect
2. Decreases the refrigeration effect
3. Increases the work of compression
4. has no effect on refrigeration effect

Question Number : 127 Question Id : 1777 Question Type : MCQ Option Shuffling : No

Correct : 2.0 Wrong : 0.0

A refrigerator with a COP of 3 user 2.4 kg/min refrigerant extracting 150 KJ/Kg heat in the evaporator. Assuming compressor efficiency of 80 %, the minimum size of the motor is

Options :

1. ✖ <https://universitynews.in>

2. ✖ 2.5 KW

3. ✖ 6 KW

4. ✖ 4.5 KW

Question Number : 128 Question Id : 1778 Question Type : MCQ Option Shuffling : No

Correct : 2.0 Wrong : 0.0

Consider the following statements. The volumetric efficiency of a reciprocating compressor depends on

- (a) Clearance factor
 - (b) Pressure ratio
 - (c) Index of expansion
 - (d) Index of compression
- of these statements

Options :

1. ✖ (a) and (b) are correct

2. ✖ (a) and (c) are correct

3. ✖ a, b, c are correct

4. ✖ a, b, d are correct

Question Number : 129 Question Id : 1779 Question Type : MCQ Option Shuffling : No

Correct : 2.0 Wrong : 0.0

Degree of reaction in an axial compressor is defined as the ratio of enthalpy rise in the

Options :

1. ✖ Rotor to the enthalpy rise in the stator

2. ✖ Stator to enthalpy rise in rotor

3. ✖ rotor to the enthalpy rise in the stage

4. ✖ stator to the enthalpy rise in the stage

Question Number : 130 Question Id : 1780 Question Type : MCQ Option Shuffling : No

Correct : 2.0 Wrong : 0.0

Consider the following turbines

- (1) Francis turbine
- (2) Pelton wheel with 2 or more jets
- (3) Pelton wheel with single jet
- (4) Kaplan

The correct sequence of these turbines in increasing order of their specific speed is

Options :

1. ✖ 2, 3, 1, 4

2. ✖ 3, 2, 1, 4

3. ✖ 2, 3, 4, 1

4. ✖ 3, 2, 4, 1

Question Number : 131 Question Id : 1781 Question Type : MCQ Option Shuffling : No

Correct : 2.0 Wrong : 0.0

List - I

Outlet Vane angle β_2

- (A) $\beta_2 < 90^\circ$
- (B) $\beta_2 = 90^\circ$
- (C) $\beta_2 > 90^\circ$

List - II

(Curves for Compressor)

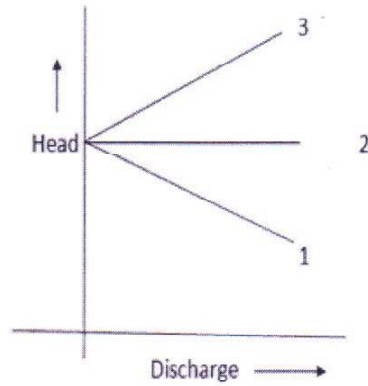

Options :

- 1. A-1, B-2, C-3
- 2. A-1, B-3, C-2
- 3. A-2, B-1, C-3
- 4. A-3, B-2, C-1

Question Number : 132 Question Id : 1782 Question Type : MCQ Option Shuffling : No

Correct : 2.0 Wrong : 0.0

Which one of the following statements is correct? Increasing the number of reheating stages in a gas turbine to infinity, makes the expansion tending to

Options :

- 1. Reversible adiabatic
- 2. Isothermal
- 3. Isobaric
- 4. Adiabatic

Question Number : 133 Question Id : 1783 Question Type : MCQ Option Shuffling : No

Correct : 2.0 Wrong : 0.0

A gas turbine cycle with regeneration and reheating improves

Options :

- 1. only thermal efficiency
- 2. only specific power output
- 3. both efficiency and power output
- 4. Neither efficiency nor power output

Question Number : 134 Question Id : 1784 Question Type : MCQ Option Shuffling : No

Correct : 2.0 Wrong : 0.0

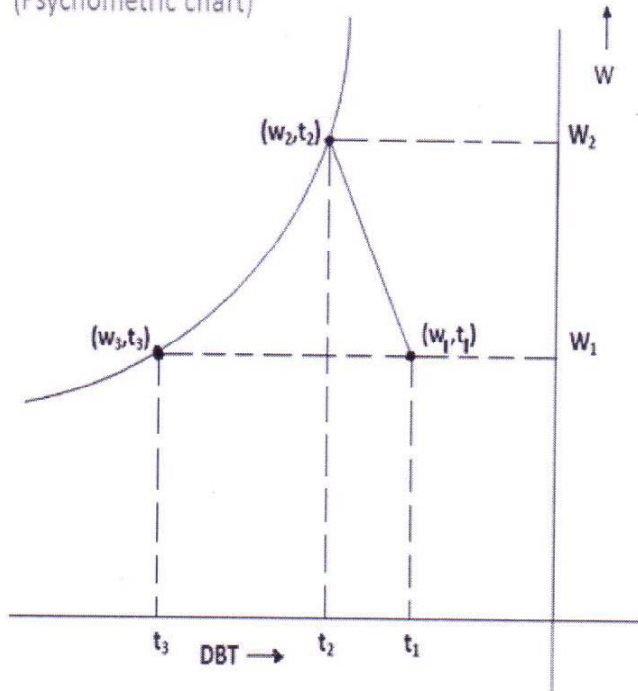

Options :

1. ✖ $t_1 \rightarrow DBT, t_2 \rightarrow DBT, t_3 \rightarrow WBT$
2. ✖ $t_1 \rightarrow DBT, t_2 \rightarrow WBT, t_3 \rightarrow DBT$
3. ✖ $t_1 \rightarrow WBT, t_2 \rightarrow DBT, t_3 \rightarrow DPT$
4. ✖ $t_1 \rightarrow DBT, t_2 \rightarrow WBT, t_3 \rightarrow DPT$

Question Number : 135 Question Id : 1785 Question Type : MCQ Option Shuffling : No
Correct : 2.0 Wrong : 0.0

An air water vapour mixture has a DBT of 60°C and a DPT of 40°C . The WBT (T_w) for the above mixture would be

Options :

1. ✖ Less than 40°C
2. ✖ 40°C
3. ✖ 60°C
4. ✖ $40^\circ\text{C} < T_w < 60^\circ\text{C}$

Question Number : 136 Question Id : 1786 Question Type : MCQ Option Shuffling : No
Correct : 2.0 Wrong : 0.0

On a Psychrometric chart, adiabatic process follows

Options :

1. ✖ Constant DBT lines
2. ✖ Constant relative humidity lines
3. ✖ Constant DPT lines
4. ✔ Constant enthalpy lines

Question Number : 137 Question Id : 1787 Question Type : MCQ Option Shuffling : No
Correct : 2.0 Wrong : 0.0

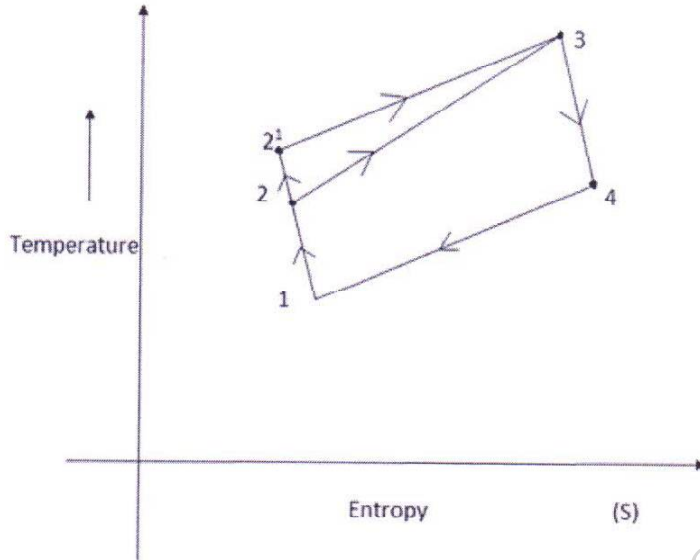

For the same maximum pressure and temperature, an otto cycle and diesel cycle are shown on T-S diagram. Which of the following is correct?

Options :

1. ✖ 1-2-3-4 is otto cycle and 2¹-3 is an isobaric process
2. ✖ 1-2¹-3-4 is an otto cycle and 2¹-3 is an isobaric process
3. ✔ 1-2-3-4 is otto cycle and 2-3 is an isochoric process
4. ✖ 1-2¹-3-4 is a Diesel cycle and 2¹-3 is an isochoric process

Question Number : 138 Question Id : 1788 Question Type : MCQ Option Shuffling : No
Correct : 2.0 Wrong : 0.0

The thermal efficiency of a Diesel cycle can be increased by

Options :

1. ✖ Increasing both compression ratio and cutoff ratio
2. ✖ Decreasing both compression ratio and cutoff ratio
3. ✖ Decreasing compression ratio and increasing cutoff ratio
4. ✔ Increasing compression ratio and decreasing cutoff ratio

Question Number : 139 Question Id : 1789 Question Type : MCQ Option Shuffling : No
Correct : 2.0 Wrong : 0.0

In case of Diesel cycle, increasing the cutoff ratio will increase

<https://universitynews.in>

- Options :
- Efficiency
 - Mean effective pressure
 - The Maximum pressure
 - The engine weight

Question Number : 140 Question Id : 1790 Question Type : MCQ Option Shuffling : No Correct : 2.0 Wrong : 0.0

Consider the following statement regarding superheating in Rankine cycle.
(1) Reduces specific steam consumption
(2) Increases dryness fraction at exhaust for the same condenser pressure
(3) It reduces cycle efficiency, of these statements

Options :

- 1 & 2 are correct
- 2 & 3 are correct
- 1 & 3 are correct
- 1, 2 & 3 are correct

Question Number : 141 Question Id : 1791 Question Type : MCQ Option Shuffling : No Correct : 2.0 Wrong : 0.0

Which combination of the following statements are correct. The incorporation of reheater in a steam power plant

- (P) Always increase thermal efficiency
(Q) Always increase dryness fraction at condensed inlet
(R) Increase the mean temperature of heat addition
(S) Always increases specific work output

Options :

- P and S
- Q and S
- P only
- Q only

Question Number : 142 Question Id : 1792 Question Type : MCQ Option Shuffling : No Correct : 2.0 Wrong : 0.0

Identify the odd one out in Casting process

Options :

- Chills
- Padding
- Inoculation
- Loam sand

Question Number : 143 Question Id : 1793 Question Type : MCQ Option Shuffling : No Correct : 2.0 Wrong : 0.0

Chills are not used in the following application

Options :

- Directional solidifications
- smaller castings for eutectic alloy
- change in crosssections
- complex geometry

<https://universitynews.in>
Question Number : 144 Question Id : 1794 Question Type : MCQ Option Shuffling : No

Correct : 2.0 Wrong : 0.0

The maximum reduction that can be given to any material in wire drawing (in most idealistic condition is)

Options :

- 53%
- 63%
- 73%
- 83%

Question Number : 145 Question Id : 1795 Question Type : MCQ Option Shuffling : No

Correct : 2.0 Wrong : 0.0

In a tensile test, neck appears in the material

Options :

- At the centre of specimen
- In the gauge length only
- Anywhere in parallel length
- Anywhere between fixed points

Question Number : 146 Question Id : 1796 Question Type : MCQ Option Shuffling : No

Correct : 2.0 Wrong : 0.0

In rolling operation, wavy edges appears due to the property of work material

Options :

- Anisotropy
- Ductility
- Toughness
- Malleability

Question Number : 147 Question Id : 1797 Question Type : MCQ Option Shuffling : No

Correct : 2.0 Wrong : 0.0

Identify the wrong statement related to yield criteria in metal forming

Options :

- stresses along hydrostatic component do not cause any plastic deformation
- Deviation component causes deformation
- Plastic deformation appears only when resultant stresses reach non-miser cylinder
- Tresca is plane strain case

Question Number : 148 Question Id : 1798 Question Type : MCQ Option Shuffling : No

Correct : 2.0 Wrong : 0.0

In the wall region of drawn cup in a deep drawing operation, the type of stresses are

Options :

- Uniaxial stretching
- tension-compression
- pure compression
- tension, compression & sheare

Question Number : 149 Question Id : 1799 Question Type : MCQ Option Shuffling : No

Correct : 2.0 Wrong : 0.0

Thickness in the drawn cup by deep drawing process keeps on increasing in the wall region because of

Options :

1. <https://universitynews.in>
2. compressive hoop stress
3. shear stress in flange region
4. Biaxial pure compression

Question Number : 150 Question Id : 1800 Question Type : MCQ Option Shuffling : No
Correct : 2.0 Wrong : 0.0

Maximum strength of the product can be achieved when it is produced by

Options :

1. open die cold working
2. close die worm working
3. impression die hot working
4. open die hot working

<https://universitynews.in>